

03



EXPANSION JOINTS

The Range

METALLIC EXPANSION JOINTS

Size : 2" to 60" (Larger sizes upon Request)

SEJ	SINGLE	Page 71
DAEJ	DOUBLE AXIAL	Page 72
UEJ	UNIVERSAL	Page 73
DMEJ	DIESEL MULTI-PLY	Page 74
DEJ	DIESEL	Page 75
DDEJ	DOUBLE DIESEL	Page 76
HEJ	SINGLE HINGE	Page 77
DHEJ	DOUBLE HINGE	Page 78
GEJ	SINGLE GIMBLE	Page 79
DGEJ	DOUBLE GIMBLE	Page 80
TEJ	SINGLE TIED	Page 81
DTEJ	DOUBLE TIED	Page 82
V-SHAPE	SEISMIC JOINT V-SHAPE	Page 87
U-SHAPE	SEISMIC JOINT U-SHAPE	Page 91
XT	EXTERNALLY PRESSURISED	Page 95
DXT	DOUBLE EXTERNALLY PRESSURISED	Page 97



SEISMIC JOINTS

Size : 1" to 6" (Larger sizes upon Request)

Page 84



PTFE EXPANSION JOINTS

Size : 1" to 12" (Larger sizes upon Request)

Page 99



RUBBER EXPANSION JOINTS

Size : 1 1/4" to 24" (Larger sizes upon Request)

Page 105



FABRIC EXPANSION JOINT

Size : 4" to 80" (Larger sizes upon Request)

Page 113



Metallic Expansion Joints Design

Introduction

Expansion joints are employed in piping systems to absorb different thermal expansion while containing the system pressure. They are successfully utilised in refineries, chemical plants, fossil and nuclear systems, heating and cooling systems, and cryogenic plants.

Any pipe connecting two points is subject to numerous types of action which result in stresses on the pipe.

Some of the causes of these stresses are:

- Internal or external pressure at working temperature
- Weight of the pipe itself and the parts supported
- Movement imposed on the pipe sections by external restraints
- Thermal expansion

The stress on the wall of piping is related to the force or movement exerted on it by external resistance and the flexibility of the pipe itself.

When either the value of the stresses or the value of the external forces or movements exceeds the maximum allowable value(s), the flexibility of the pipe must be increased artificially. This can be done either by altering the layout of the pipe or by inserting high flexibility sections.

This is precisely the function of expansion joints.

Depending on the type of movement to be absorbed, expansion joints can be classified as follows:

- Axial
- Universal
- Angular (hinged)
- Spherical angular (gimbal)
- Lateral
- Spherical lateral
- Pressure balance axial
- Pressure balance universal



Design and Manufacture

Pacific Hoseflex has a variety of different size expansion joints available from 50 mm to 5000 mm in diameter, with working pressures up to 10,000 kPa. Consideration must be taken into account when elevated temperatures are involved. They reduce both rated movement for a given life cycle and pressure capabilities of the expansion joint.

Bellows operate best at normal pressure ratings temperatures between 70° C to 80° C. The austenitic range of stainless steel is susceptible to high stresses in the presence of corrosive agents, such as chlorides, caustic alkalis, hydrogen sulfide and nitrates.

Definition of Movement

Axial Movement

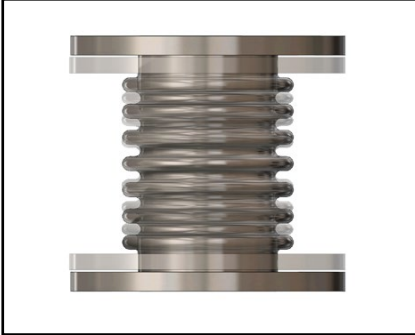

Axial Compression is the dimensional shortening of an Expansion Joint along its longitudinal axis while axial extension is the dimensional lengthening of the expansion joint.

Lateral Movement

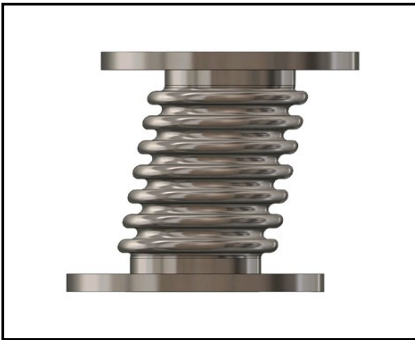

Lateral Deflection is the relative displacement of the two ends of an Expansion Joint perpendicular to its longitudinal axis.

Angular Movement

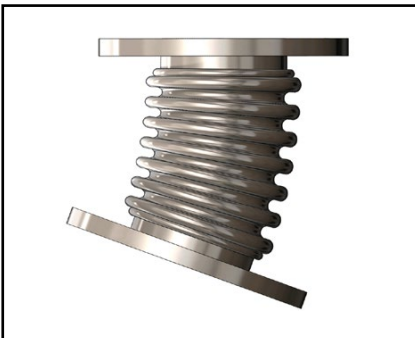

Angular Rotation is the displacement of the longitudinal axis of the Expansion Joint from its initial straight line position into a circular arc.

Cycle Life & Quality Management

Cycle Life

This is the anticipated number of complete expansions and contractions that a bellow can accommodate in its working life. This is an important consideration with bellow design. This consideration is to ensure the correct balance between the pressure containing characteristics and the movement.

The cycle life expectancy of an expansion joint is affected by the following various factors:

- operating pressure
- operating temperature
- the material from which the bellows is made
- the movement per convolution
- the thickness of the bellow
- the convolution pitch
- depth and shape of convolution

After installation, any change to any of these factors will impact upon the cycle life.



Asset (Hose) Management System

Pacific Hoseflex has developed and implemented a Asset (Hose) Management System to offer clients complete traceability. Our system is flexible and can be customized to accommodate the specific needs of individual clients

With accredited Quality Assurance:

- ISO 9001 Quality
- ISO 14001 Environmental
- ISO 45001 Safety

Pacific Hoseflex quality control measures, inspection and testing procedures include; inwards goods inspection, in-process inspection, final product release inspection and leak detection inspection. There are several different methods for leak detection: dye penetrate examination, X-ray examinations, magnetic particle inspection, hydrostatic test and pneumatic test.



Bellow Forming & Material

Bellows forming

The basic method(s) of bellows manufacture is not complicated. There are two ways that a bellows can be manufactured:

1. Mechanical forming can be done by either rolling the convolutions between external and internal wheels.
2. Hydraulic forming, using internal pressure has a much greater life than bellows formed by the other method(s). Bellows shall be hydraulically formed from a tube having only longitudinal seams. When the ratio of corrugation diameter to shell diameter is large, as in small diameter bellows, the units shall be annealed to remove stresses created by the forming operation.

The number of convolutions depends upon the amount of movement the bellows must accommodate or the force that must be used to accomplish the deflection. Since bellows are unique, there are many design considerations which must be evaluated. The convoluted element must be strong enough circumferentially to withstand the line pressure of the system, yet responsive enough longitudinally to flex. The longitudinal load (pressure thrust) must then be absorbed by some other type of device. These are usually anchors, tie rods, hinges or gimbal structures.

Under pressure a bellows will crave to squirm. This can occur when a bellow is subjected to a pressure greater than 1.5 times the design pressure. Squirm can be considered the same as column buckling in a beam under compressive loading. The convolutions deform and even though there is no leaking, both cycle life and pressure capacity is greatly reduced.

Bellows Material

Stainless Steel 304

Is a lower grade material than 321 SS with less resistance to corrosion. Applications include diesel engine exhaust manifolds and steam.

Stainless Steel 321

The most common material used for bellow manufacture. It combines excellent mechanical properties with adequate corrosion resistance. Applications include diesel engine exhaust manifolds and steam.

Stainless Steel 316

Has a better corrosion resistance than 321 SS and can be used as an alternative to Incoloy 825. Applications include engine exhaust manifolds, steam and marine services.

Incoloy 825, 800

A high nickel alloy specifically designed for use in aggressive environment. It is very resistant to pitting and crevice corrosion and virtually immune to stress corrosion cracking. It can be used up to a maximum temperature of 425° C. Applications include diesel engine exhaust manifolds, steam, crude oil lines and flue gases.

Inconel 625, 600 and 800

Is a high nickel alloy with good corrosion resistant and temperature capability higher than 425° C.

Nickel 200, 253 MA

This alloy has good mechanical properties and excellent corrosion resistance to alkalis, i.e. sodium hydroxide. It also has good electrical, thermal and magneto-strictive properties. Applications include food and synthetic fibre processing, heat exchangers, chemical and electrical industries.

Hastelloy

It has a high-strength, nickel based, corrosion resistant alloy. Other components include molybdenum and chromium. It is well suited for most chemical applications. It has excellent resistance to pitting, stress-corrosion and cracking

254 SMO

This is a very high end austenitic stainless steel that combines impact toughness resistance to chloride stress corrosion cracking, pitting and crevice corrosion with strength nearly twice that of 300 series stainless steels. In some applications it has been found to be a more cost effective substitute for high nickel and titanium alloys.



Liners

Single Liners

Liners are used to prevent flow induced vibration or erosion caused by abrasive materials. When lateral movement is required in the expansion joint, the flow liner diameter must be reduced to provide clearance.

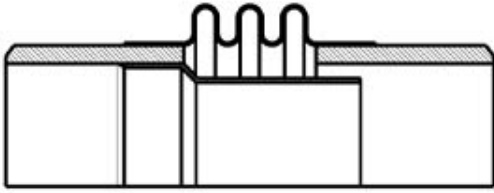

Single Welded Liner

Most common type of internal liner.
Maximum durability.

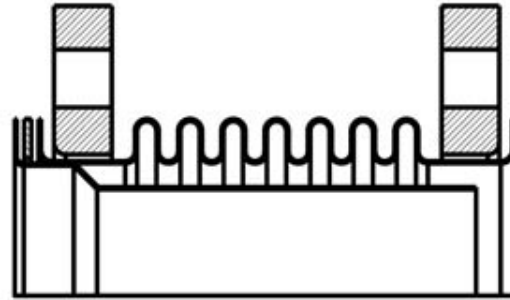

Single Drop-In Liner

Can be removed and cleaned.

Telescopic Liners

Telescoping liners are used on short expansion joints with large axial movements. When fit close together, they can also be used in systems where the flow can be in either direction.

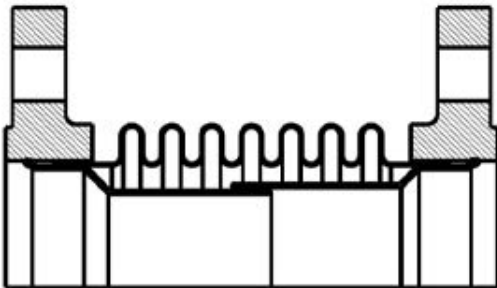

Telescoping Welded Liner

For large axial movements.

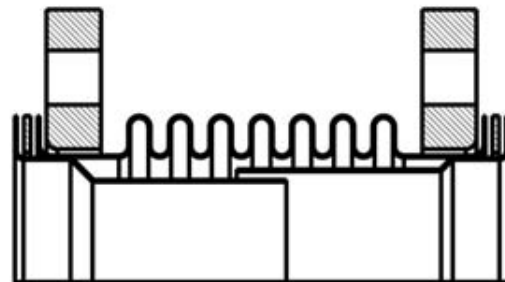

Telescoping Drop-In Liner

For large axial movements. Can be removed and cleaned.

Rods Restraints

Restraints

Restraints are used for lateral and angular compensators. The restraints absorb axial reaction force produced by inner pressure. Even so, the connected pipe must be equipped with light fixed points to absorb moving force and moments. Precise rating details and operating parameters of the corresponding machinery or equipment must be known to correctly calculate the degree of restraints.

Rubber Expansion Joint Rod Restraints

There are two types of tie rods restraints for lateral rubber compensators:

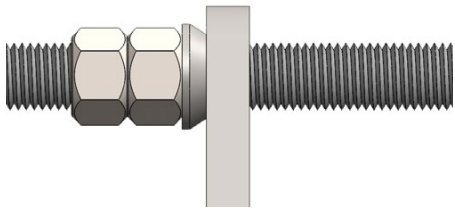

Outer restraints are used to absorb reaction force from internal pressure

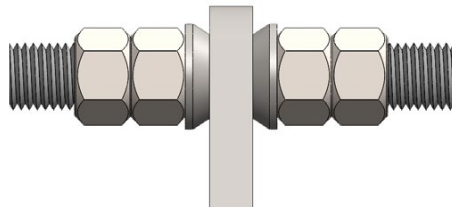

Outer and inner restraints are used to absorb reaction force from internal pressure and vacuum



Metallic Expansion Joint Rod Restraints

Lateral compensators are equipped with adapters for tie rods restraints. The design differs between flanges with welded ears or oval flanges depending on compensator type and size. Tie rods restraints run conical seats.

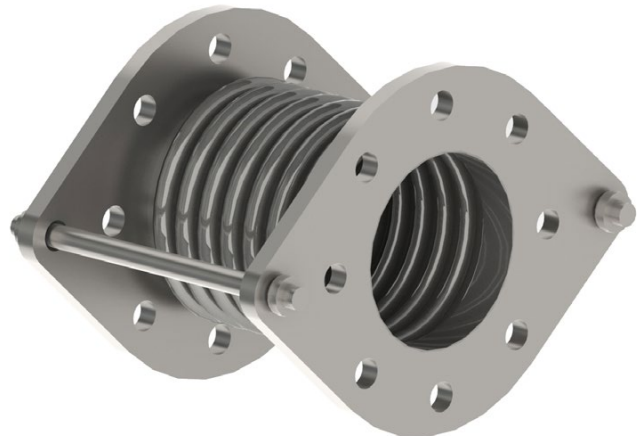
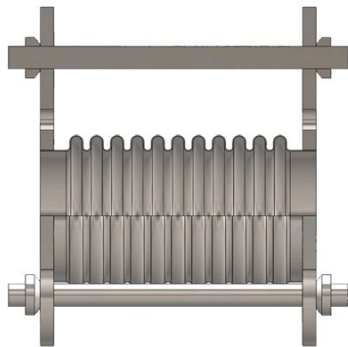

Pipe Supports & Hangers

Insulated Pipe Clamps

Made from thicker material and can withstand greater loads and movement/strong vibrations making it a safe and reliable solution for supporting emergency high pressure fire sprinkler system pipework. The weld nut on all sizes is designed for M12 threaded rod. Zinc Plated to AS1789:2003 to meet grade Fe/Zn12 as a standard material finish.



Clevis Hanger

Recommended for the suspension of stationary non-insulated pipe lines. Also commonly used for the suspension of insulated pipe lines, Flared edges help prevent sharp surfaces from coming into contact with the pipe. Clevis bottom pivots to allow pipe to be fed from either direction.



U Bolt Support

Heavy duty insulated U bolt that is supplied with a 10mm thick cork and neoprene base. It is designed to provide support for large heavy weight pipes made out of stainless steel, duplex/super duplex or other materials.



Clamped Pipe Support

Clamped Pipe Shoe supports pipe nominal bores from 25NB through to 1150NB are manufactured from material to meet AS/NZS1594:2002 and either Hot Dip Galvanised to AS4680:2006 or available in Stainless Steel.



Saddle Pipe Support

Saddle Clamps to suit Steel Pipe for general plumbing are manufactured from material to meet AS/NZS1594:2002, and Hot Dip Galvanised to meet AS/NZS4680:2006 or available in Stainless Steel.



Chain

Strong and durable, use this heat-treated chain when using fittings with chain. You must match the chain size and meet or exceed the chain's grade.



Channel and Struts

Can be supplied in lengths of 41mm wide channel/strut with a choice of thicknesses, heights and materials. Channel provides an ideal mechanical support frame for a range of applications, and is a great starting point for installing electrical cable or pipe management systems. It can be provided in plain style, slotted with evenly spaced slots along its length, or in a range of different welded combinations. Other variants allow for easy installation/securing of the product into concrete.

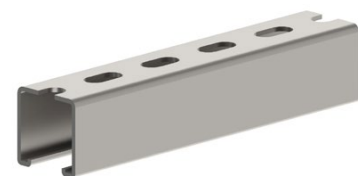

Metallic Expansion Joints Installation Guide

Storage:

1. Store expansion joints in a dry/cool location such as a warehouse.
2. Store flange face down on a pallet or wooden platform.
3. Do not store other heavy items on top of expansion joint (s).
4. Ten-year shelf life can be expected with ideal conditions.

Handling:

Do not lift with ropes or bars through the bolt holes. If lifting through the bore, use padding or a saddle to distribute the weight. Do not let expansion joints sit vertically on the edges of the flanges for any period of time. Do not lift on the shipping restraints.

Service Conditions:

Make sure the expansion joint rating for temperature, pressure, movements, and selection of materials match the system requirements. Contact the manufacturer if the system requirements exceed those of the expansion joint selected.

Alignment:

Expansion joints are not designed to make up for piping misalignment errors. Check with the manufacturer if piping misalignment is present.

Anchoring:

The main function of expansion joints is to compensate for axial pipe thermal expansion. Metal expansion joints must have the protection of adequate anchoring against the internal and thrust pressures of the media to prevent damage. Anchoring must be installed as close to the down stream end of the expansion joint as possible, with the originating equipment serving as the opposite anchor. Anchors must prevent pipe movement in any direction. Hangers or pipe pedestals cannot be considered to be anchors as they offer no restriction against side or end motion.

When designing an anchor for a metal expansion joint, consult the internal thrust force table from the appropriate expansion joint catalogue. The weight of piping, valves, and media, as well as the resistance of the piping to deflection, must be included as part of the design weight and strength of an anchor.

Anchors are required whenever a piping system changes direction. Expansion joints should be located as close as possible to anchor points. For additional expansion joint protection, it is recommended that control rods be installed on the expansion joint to prevent excessive movements from occurring due to pressure thrust of the line.

Guides:

Expansion joints must be properly guided and anchored in accordance with EJMA standards. (Refer to Pipe Guides Spacing Diagram below)

Pipe Support:

Piping must be supported so expansion joints do not carry any pipe weight.

Pipe Guides - Spacing Diagram

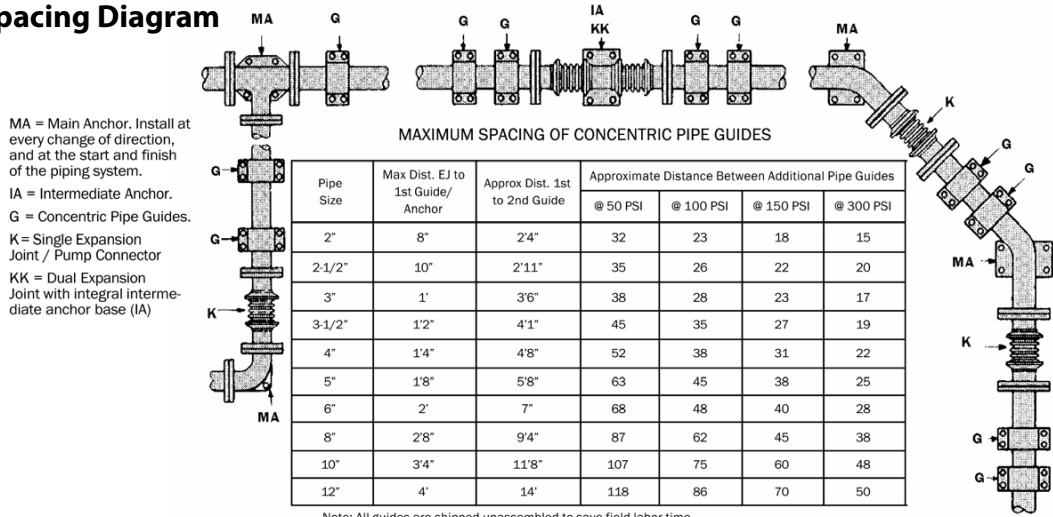



Metallic Expansion Joints Installation Guide

Mating Flanges:

Install the expansion joint flange against the mating pipe flanges and install bolts so that the bolt head is against the expansion joint flange. Bolts should be installed from the bellows side (so that the bolt heads are adjacent to the bellows) to insure that the bolts do not interfere with the bellows during periods of compression. Flange-to-flange dimensions of the expansion joint must match the required opening.

Make sure mating flanges are clean and are matched to the type supplied with the expansion joint. Gaskets of appropriate material, size and temperature ratings must be used in all flange-to-flange type installations.

Bolt Torque:

Tighten bolts in stages by alternating around the flange. Never tighten an expansion joint to the point that there is metal-to-metal contact between the expansion joint flange and the mating flange.

Shipping Restraints:

The expansion and compression movements are preset at the factory. The shipping restraints protect the expansion joint in its neutral position prior to installation. Remove the shipping restraints after installation and before hydro-testing the system.

Additional Tips:

1. Insulation or thermal blankets over a metal expansion joint should be supplied by the expansion joint manufacturer to preclude the use of corrosive chloride bearing insulation materials. Insulation should be installed to permit easy access to the flange area, to check bolting.
2. Do not weld in the near vicinity of a non-shrouded expansion joint without protecting the expansion joint from damaging weld splatter.
3. If an expansion joint is to be installed underground, or will be submerged in water, contact the manufacturer for specific guidelines.
4. Consider ordering a spare expansion joint. The cost of downtime of a critical expansion joint far exceeds the cost of a spare unit placed and protected in reserve on-site.
5. Whenever possible, install the expansion joint next to an anchor as indicated below not exceeding maximum distance to the 1st guide with at least two concentric pipe guides on the opposite side of the joint. Added guides are required to prevent bowing or bending of the pipe.
6. When an expansion joint is placed elsewhere in the line, at least two concentric guides must be used on each side of the joint with added joints installed as recommended in pipe guide spacing diagram.
7. The inside of all piping must be clean before installing and testing the expansion joints. Expansion joints should not be subjected to hydrostatic pressure tests beyond their rated working pressure.
8. Secure all anchors and guides before testing. Remove shipping bars prior to testing.
9. Expansion joints must be removed from the lines while the system is being tested hydrostatically at pressure exceeding allowable working pressure.
10. Expansion Joints fabricated with flow liners must be installed with the flow arrow pointing in the same direction of the media flow.
11. Single externally pressurized expansion joints must be installed with the moving end adjacent to the moving end of the pipe responding to the thermal expansion induced during system heat-up.
12. Failure to install according to instructions will void warranty.



EXPANSION JOINTS

Single Expansion Joint (SEJ)

Expansion Joint - SEJ

Part No.: SEJ

Construction: Convoluted

Material: 304, 321, 316, Incoloy, Inconel, Nickel, Hastelloy

Profile: Medium Flexibility / High Pressure

Liner: Optional

Size Available: 2" - 40"

(Larger sizes upon Request)

Temperature: -196°C +900°C

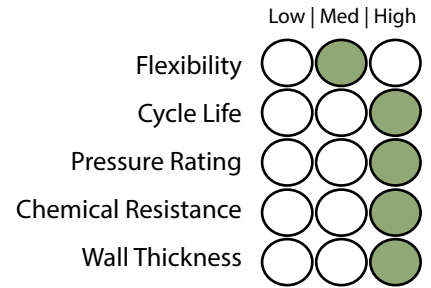

Construction

Use:

Used for absorbing axial, angular and small amounts of lateral movement. Pressure thrust will be transmitted onto the pipeline.



Specifications

Part Number	Nom	Length		Max. Working Pressure kPa	Movements			Spring Rate N/MM	Pressure Thrust KN
	Bore	Flanged	Weld Ends		Axial	Lateral	Angular		
	(mm)	(mm)	(mm)		(mm)	(mm)	(Deg)		
50 SEJ-240	50	145	218	240	32	12	18	21	1
50 SEJ-700	50	145	218	700	21	8	18	21	3
50 SEJ-1400	50	145	218	1400	18	7	18	70	6
65 SEJ-240	65	180	234	240	36	12	18	19	2
65 SEJ-700	65	180	234	700	28	11	18	57	4
65 SEJ-1400	65	180	234	1400	22	7	18	102	9
80 SEJ-240	80	180	278	240	34	13	18	12	2
80 SEJ-700	80	180	278	700	34	13	18	36	6
80 SEJ-1400	80	180	278	1400	25	8	17	130	12
100 SEJ-240	100	190	278	240	36	13	18	47	3
100 SEJ-700	100	190	278	700	32	10	18	84	9
100 SEJ-1400	100	190	278	1400	27	7	14	169	19
125 SEJ-240	125	215	313	240	50	13	18	50	4
125 SEJ-700	125	215	313	700	37	10	18	87	14
125 SEJ-1400	125	215	313	1400	27	7	14	169	27
150 SEJ-240	150	215	338	240	50	15	18	50	6
150 SEJ-700	150	215	338	700	39	9	18	72	19
150 SEJ-1400	150	215	338	1400	26	6	14	330	39
200 SEJ-240	200	225	330	240	57	16	18	28	11
200 SEJ-700	200	225	330	700	47	9	17	105	33
200 SEJ-1400	200	225	330	1400	30	6	13	541	66
250 SEJ-240	250	245	341	240	64	17	18	27	17
250 SEJ-700	250	245	341	700	62	10	18	120	51

Additional sizes available. Visit www.hoseflex.com for our complete range

EXPANSION JOINTS 1 2 3 4 5 6 7 8 9



EXPANSION JOINTS

Double Axial Expansion Joint (DAEJ)

Expansion Joint - DAEJ

Part No.: DAEJ

Construction: Convoluted

Material: 304, 321, 316, Incoloy, Inconel, Nickel, Hastelloy

Profile: Medium Flexibility / High Pressure

Liner: Standard Flow Liner

Size Available: 2" - 24"

(Larger sizes upon Request)

Temperature: -196°C +900°C

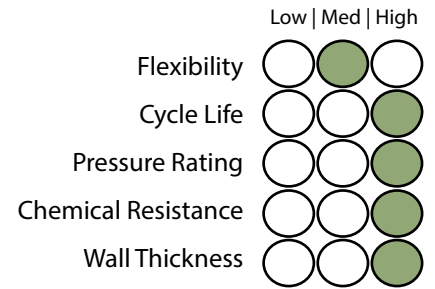

Construction

Use:

Used for absorbing large amounts of axial movement. Pressure thrust will be transmitted onto the pipeline. Correct anchoring and guiding must be used. Internal flow liner for eliminating velocity and flow problems is fitted as standard.



Specifications

Part Number	Nom	Length		Max. Working Pressure kPa	Axial Movement (mm)	Spring Rate N/MM	Pressure Thrust KN
	Bore	Flanged	Weld Ends				
	(mm)	(mm)	(mm)				
50 DAEJ-240	50	380	440	240	64	11	1
50 DAEJ-700	50	380	440	700	42	35	3
50 DAEJ-1400	50	380	440	1400	36	35	6
65 DAEJ-240	65	450	440	240	72	10	2
65 DAEJ-700	65	450	440	700	56	29	4
65 DAEJ-1400	65	450	440	1400	44	51	9
80 DAEJ-240	80	450	440	240	68	6	2
80 DAEJ-700	80	450	440	700	68	18	6
80 DAEJ-1400	80	450	440	1400	50	65	12
100 DAEJ-240	100	450	580	240	72	24	3
100 DAEJ-700	100	450	580	700	64	42	9
100 DAEJ-1400	100	450	580	1400	46	85	19
125 DAEJ-240	125	450	580	240	100	25	4
125 DAEJ-700	125	450	580	700	72	44	14
125 DAEJ-1400	125	450	580	1400	52	85	27
150 DAEJ-240	150	450	580	240	102	21	6
150 DAEJ-700	150	450	580	700	78	36	19
150 DAEJ-1400	150	450	580	1400	52	165	39
200 DAEJ-240	200	450	580	240	114	14	11
200 DAEJ-700	200	450	580	700	94	53	33
200 DAEJ-1400	200	450	580	1400	60	271	66
250 DAEJ-240	250	470	582	240	128	14	17
250 DAEJ-700	250	470	582	700	124	60	51

Additional sizes available. Visit www.hoseflex.com for our complete range

9
8
7
6
5
4
3
2
1

EXPANSION JOINTS

Universal Expansion Joint (UEJ)

Expansion Joint - UEJ

Part No.: UEJ

Construction: Convoluted

Material: 304, 321, 316, Incoloy, Inconel, Nickel, Hastelloy

Profile: Medium Flexibility / High Pressure

Liner: Optional

Size Available: 2" - 60"

(Larger sizes upon Request)

Temperature: -196°C +900°C

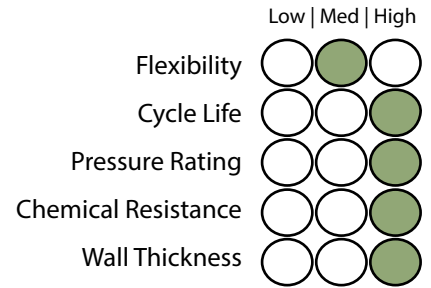

Construction

Use:

Used for absorbing large amounts of axial, angular and lateral movement in low pressure pipelines. Pressure thrust will be transmitted onto the pipeline.



Specifications

Part Number	Nom	Length		Max. Working Pressure	Movements			Spring Rate	Pressure Thrust
	Bore	Flanged	Weld Ends		Axial	Lateral	Angular		
	(mm)	(mm)	(mm)		(mm)	(mm)	(Deg)		
50 UEJ-200	50	380	460	200	64	76	18	11	0.8
65 UEJ-200	65	380	460	200	64	76	18	10	1.4
80 UEJ-200	80	380	460	200	70	76	18	6	1.8
100 UEJ-200	100	430	526	200	72	76	18	24	2.8
125 UEJ-200	125	430	526	200	106	130	18	25	4.0
150 UEJ-200	150	430	576	200	106	120	18	21	5.6
200 UEJ-200	200	450	560	200	114	98	18	14	9.4
250 UEJ-200	250	485	582	200	112	98	18	14	14.8
300 UEJ-200	300	555	700	200	152	114	18	14	20
350 UEJ-200	350	540	736	200	178	114	18	30	24
400 UEJ-200	400	540	736	200	178	114	18	43	30
450 UEJ-200	450	540	772	200	182	102	18	49	38
500 UEJ-200	500	540	772	200	182	102	16	37	46
600 UEJ-200	600	540	772	200	148	86	16	45	66
650 UEJ-200	650	690	790	200	108	72	15	72	76
700 UEJ-100	700	690	790	100	111	72	15	82	43
750 UEJ-100	750	690	790	100	119	70	15	71	50
800 UEJ-100	800	690	790	100	122	64	15	74	58
850 UEJ-100	850	690	790	100	112	60	15	79	64
900 UEJ-100	900	690	790	100	112	59	15	87	71
950 UEJ-100	950	690	790	100	120	57	15	93	79
1000 UEJ-100	1000	1190	1290	100	120	54	14	121	85
1050 UEJ-100	1050	1190	1290	100	78	68	14	127	96

Additional sizes available. Visit www.hoseflex.com for our complete range



EXPANSION JOINTS

Diesel Multi-ply Expansion Joint (DMEJ)

Expansion Joint - DMEJ

Part No.: DMEJ
Construction: Convoluted
Material: 304, 321, 316, Incoloy, Inconel, Nickel, Hastelloy
Profile: Medium Flexibility / High Pressure
Liner: Standard Flow Liner
Size Available: 2" - 60"
(Larger sizes upon Request)
Temperature: -196°C +900°C

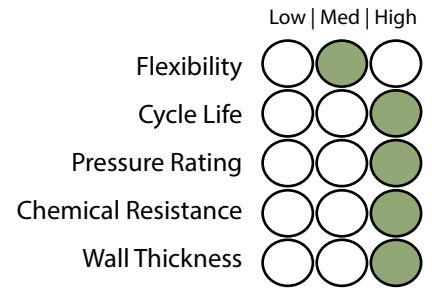

Construction

Use:
 Used for vibration and absorbing thermal expansion in exhaust, gas ducting and low pressure systems. Relieves stresses caused by vibration. Specially designed multi ply element. Internal flow liners for eliminating velocity and flow problems fitted as standard.



Specifications

Part Number	Nom	Length		Max. Working Pressure	Movements			Spring Rate	Pressure Thrust
	Bore	Flanged	Weld Ends		Axial	Lateral	Angular		
	(mm)	(mm)	(mm)		(mm)	(mm)	(Deg)		
50 DMEJ-100	50	145	218	100	16	4	12	59	0.4
65 DMEJ-100	65	180	234	100	29	5	14	36	0.7
80 DMEJ-100	80	180	240	100	26	6	14	26	0.9
100 DMEJ-100	100	190	278	100	28	6	14	63	1.4
125 DMEJ-100	125	215	313	100	28	7	14	69	2.0
150 DMEJ-100	150	215	338	100	26	8	14	78	2.8
200 DMEJ-100	200	225	330	100	39	8	13	106	4.7
250 DMEJ-100	250	330	400	100	84	10	14	38	7.4
300 DMEJ-100	300	330	400	100	86	11	14	44	10
350 DMEJ-100	350	330	400	100	88	11	14	46	12
400 DMEJ-100	400	330	400	100	76	10	13	64	15
450 DMEJ-100	450	330	400	100	78	11	13	68	19
500 DMEJ-100	500	330	400	100	81	12	13	75	23
600 DMEJ-100	600	330	400	100	84	10	12	88	33
650 DMEJ-100	650	400	460	100	84	10	14	132	38
700 DMEJ-100	700	400	460	100	84	10	14	136	43
750 DMEJ-100	750	400	490	100	96	12	14	123	50
800 DMEJ-100	800	400	490	100	96	12	14	129	58
850 DMEJ-100	850	400	490	100	98	11	13	139	64
900 DMEJ-100	900	400	490	100	98	10	13	146	71
950 DMEJ-100	950	400	490	100	90	10	13	153	79
1000 DMEJ-100	1000	400	490	100	90	9	10	166	85
1050 DMEJ-100	1050	400	490	100	90	8	10	164	96

Additional sizes available. Visit www.hoseflex.com for our complete range



EXPANSION JOINTS

Diesel Expansion Joint (DEJ)

Expansion Joint - DEJ

Part No.: DEJ

Construction: Convoluted

Material: 304, 321, 316, Incoloy, Inconel, Nickel, Hastelloy

Profile: Medium Flexibility / Low Pressure

Liner: Standard Flow Liner

Size Available: 2" - 60"

(Larger sizes upon Request)

Temperature: -196°C +900°C

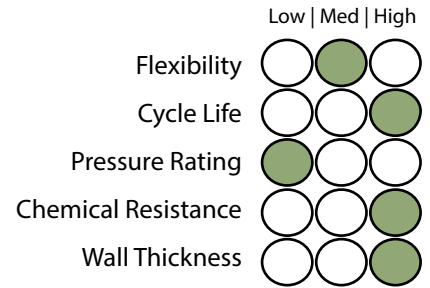

Construction

Use:

Used for absorbing thermal expansion in exhaust, gas ducting and low pressure systems. Pressure thrust will be transmitted onto pipeline. Internal flow liners for eliminating velocity and flow problems fitted as standard.



Specifications

Part Number	Nom	Length		Max. Working Pressure kPa	Movements			Spring Rate N/MM	Pressure Thrust KN
	Bore	Flanged	Weld Ends		Axial	Lateral	Angular		
	(mm)	(mm)	(mm)		(mm)	(mm)	(Deg)		
50 DEJ-100	50	145	218	100	36	12	18	21	0.4
65 DEJ-100	65	180	234	100	39	12	18	19	0.7
80 DEJ-100	80	180	240	100	44	13	18	12	0.9
100 DEJ-100	100	190	278	100	44	13	18	47	1.4
125 DEJ-100	125	215	313	100	50	13	18	50	2.0
150 DEJ-100	150	215	338	100	54	15	18	42	2.8
200 DEJ-100	200	225	330	100	59	16	18	28	4.7
250 DEJ-100	250	245	341	100	70	17	18	27	7.4
300 DEJ-100	300	280	400	100	82	18	18	28	10
350 DEJ-100	350	270	418	100	89	15	18	59	12
400 DEJ-100	400	270	418	100	96	10	17	86	15
450 DEJ-100	450	270	436	100	96	8	15	97	19
500 DEJ-100	500	270	436	100	98	9	14	74	23
600 DEJ-100	600	270	436	100	96	7	12	90	33
650 DEJ-100	650	385	460	100	107	12	15	76	38
700 DEJ-100	700	385	460	100	107	12	15	81	43
750 DEJ-100	750	385	460	100	107	12	15	65	50
800 DEJ-100	800	385	460	100	104	11	15	71	58
850 DEJ-100	850	385	460	100	104	11	14	73	64
900 DEJ-100	900	385	460	100	100	10	14	81	71
950 DEJ-100	950	385	460	100	100	9	12	84	79
1000 DEJ-100	1000	330	415	100	96	6	10	108	85
1100 DEJ-100	1100	330	415	100	96	5	9	113	116

Additional sizes available. Visit www.hoseflex.com for our complete range

EXPANSION JOINTS 1 2 3 4 5 6 7 8 9



EXPANSION JOINTS

Double Diesel Expansion Joint (DDEJ)

Expansion Joint - DDEJ

Part No.: DDEJ

Construction: Convuluted

Material: 304, 321, 316, Incoloy, Inconel, Nickel, Hastelloy

Profile: Medium Flexibility / Low Pressure

Liner: Standard Flow Liner

Size Available: 2" - 60"
(Larger sizes upon Request)

Temperature: -196°C +900°C

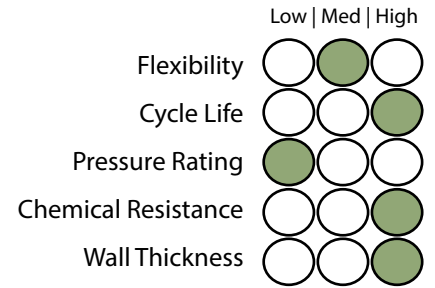

Construction

Use:

Used for absorbing large amounts of axial angular and lateral movements in low pressure pipelines. Pressure thrust will be transmitted onto pipeline. Internal flow liners for eliminating velocity & flow problems fitted as standard.



Specifications

Part Number	Nom	Length		Max. Working Pressure	Movements			Spring Rate	Pressure Thrust
	Bore	Flanged	Weld Ends		Axial	Lateral	Angular		
	(mm)	(mm)	(mm)		(mm)	(mm)	(Deg)		
50 DDEJ-100	50	380	460	100	64	76	18	11	0.4
65 DDEJ-100	65	380	460	100	64	76	18	16	0.7
80 DDEJ-100	80	380	460	100	70	76	18	6	0.9
100 DDEJ-100	100	430	526	100	76	76	18	24	1.4
125 DDEJ-100	125	430	526	100	106	130	18	25	2.0
150 DDEJ-100	150	430	576	100	106	120	18	21	2.8
200 DDEJ-100	200	450	560	100	114	98	18	14	4.7
250 DDEJ-100	250	485	582	100	112	98	18	14	7.4
300 DDEJ-100	300	555	700	100	152	114	18	14	10
350 DDEJ-100	350	540	736	100	178	114	18	30	12
400 DDEJ-100	400	540	736	100	178	114	18	43	15
450 DDEJ-100	450	540	772	100	182	102	18	49	19
500 DDEJ-100	500	540	772	100	182	102	16	37	23
600 DDEJ-100	600	540	854	100	148	86	16	45	33
650 DDEJ-100	650	690	790	100	108	72	15	72	38
700 DDEJ-100	700	690	790	100	111	72	15	82	43
750 DDEJ-100	750	690	790	100	119	70	15	71	50
800 DDEJ-100	800	690	790	100	122	64	15	74	58
850 DDEJ-100	850	690	790	100	112	60	15	79	64
900 DDEJ-100	900	690	790	100	112	59	15	87	71
950 DDEJ-100	950	690	790	100	120	57	15	93	79
1000 DDEJ-100	1000	1190	1290	100	120	54	14	121	85
1050 DDEJ-100	1050	1190	1290	100	78	68	14	127	96

Additional sizes available. Visit www.hoseflex.com for our complete range



EXPANSION JOINTS

Single Hinge Expansion Joint (HEJ)

Expansion Joint - HEJ

Part No.: HEJ

Construction: Convoluted

Material: 304, 321, 316, Incoloy, Inconel, Nickel, Hastelloy

Profile: Medium Flexibility / High Pressure

Liner: Optional

Size Available: 2" - 24"

(Larger sizes upon Request)

Temperature: -196°C +900°C

Low | Med | High

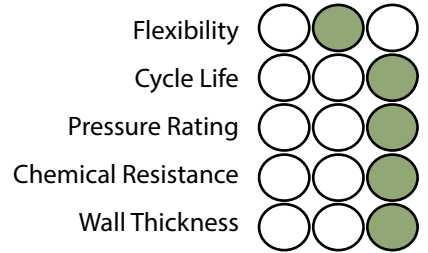

Construction

Use:

Used for absorbing angular movement in one plane only, movement of bellows is more controlled. Pressure thrust is restrained by the hinges.

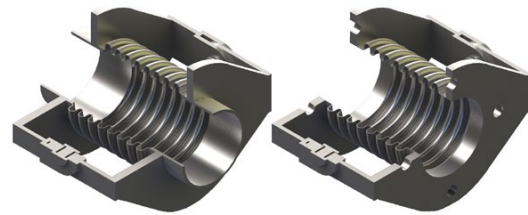

Specifications

Part Number	Nom	Length		Max. Working Pressure kPa	Movements		Spring Rate NM/Deg
	Bore	Flanged	Weld Ends		± Degrees	Total Degrees	
	(mm)	(mm)	(mm)		(mm)	(mm)	
50-HEJ-240	50	145	218	240	18	36	0.2
50-HEJ-700	50	145	218	700	18	36	0.6
50-HEJ-1400	50	145	218	1400	18	36	0.6
65-HEJ-240	65	180	234	240	18	36	0.2
65-HEJ-700	65	180	234	700	18	36	0.7
65-HEJ-1400	65	180	234	1400	18	36	1.3
80-HEJ-240	80	180	240	240	18	36	0.2
80-HEJ-700	80	180	240	700	18	36	0.6
80-HEJ-1400	80	180	240	1400	17	34	2.2
100-HEJ-240	100	190	278	240	18	36	0.3
100-HEJ-700	100	190	278	700	18	36	2.2
100-HEJ-1400	100	190	278	1400	17	34	4.6
125-HEJ-240	125	215	313	240	18	36	1.9
125-HEJ-700	125	215	313	700	18	36	3.4
125-HEJ-1400	125	215	313	1400	14	28	6.6
150-HEJ-240	150	215	338	240	18	36	2.3
150-HEJ-700	150	215	338	700	18	36	3.9
150-HEJ-1400	150	215	338	1400	14	28	18.2
200-HEJ-240	200	225	330	240	18	36	2.6
200-HEJ-700	200	255	330	700	17	34	9.8
200-HEJ-1400	200	255	330	1400	13	26	50
250-HEJ-240	250	245	341	240	18	36	4
250-HEJ-700	250	245	341	700	18	36	17

Additional sizes available. Visit www.hoseflex.com for our complete range



EXPANSION JOINTS

Double Hinge Expansion Joint (DHEJ)

Expansion Joint - DHEJ

Part No.: DHEJ

Construction: Convolute

Material: 304, 321, 316, Incoloy, Inconel, Nickel, Hastelloy

Profile: Medium Flexibility / High Pressure

Liner: Optional

Size Available: 2" - 24"

(Larger sizes upon Request)

Temperature: -196°C +900°C

Low | Med | High

Flexibility

Cycle Life

Pressure Rating

Chemical Resistance

Wall Thickness

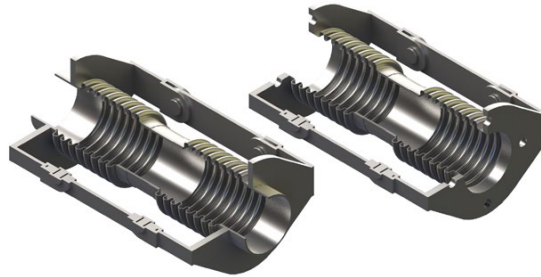

Use:

Used for absorbing large amounts of lateral movement in one plane, Movement of bellows is more controlled. Anchors only required to absorb.

Specifications

Part Number	Nom	Length		Max. Working Pressure	Movements		Spring Rate
	Bore	Flanged	Weld Ends		± Lateral	Total Lateral	
	(mm)	(mm)	(mm)		(mm)	(mm)	
50 DHEJ-240	50	600	632	240	94	188	0.1
50 DHEJ-700	50	600	632	700	94	188	0.4
50 DHEJ-1400	50	600	632	1400	94	188	0.4
65 DHEJ-240	65	600	632	240	81	162	0.3
65 DHEJ-700	65	600	632	700	81	162	0.8
65 DHEJ-1400	65	600	632	1400	81	162	1.3
80 DHEJ-240	80	600	632	240	76	152	0.3
80 DHEJ-700	80	600	632	700	76	152	1.2
80 DHEJ-1400	80	600	632	1400	76	152	4.2
100 DHEJ-240	100	600	632	240	64	128	1.4
100 DHEJ-700	100	600	632	700	64	128	2.5
100 DHEJ-1400	100	600	632	1400	64	128	5.1
125 DHEJ-240	125	600	761	240	88	176	1.6
125 DHEJ-700	125	600	761	700	88	176	2.7
125 DHEJ-1400	125	600	761	1400	88	176	5.2
150 DHEJ-240	150	619	813	240	88	176	2.2
150 DHEJ-700	150	619	813	700	88	176	3.7
150 DHEJ-1400	150	619	813	1400	88	176	16.9
200 DHEJ-240	200	698	892	240	106	212	1.8
200 DHEJ-700	200	698	892	700	106	212	6.8
200 DHEJ-1400	200	698	892	1400	106	212	35
250 DHEJ-240	250	800	994	240	112	224	3
250 DHEJ-700	250	800	994	700	112	224	17

Additional sizes available. Visit www.hoseflex.com for our complete range

EXPANSION JOINTS 1 2 3 4 5 6 7 8 9

Single Gimbal Expansion Joint (GEJ)

Expansion Joint - GEJ

Part No.: GEJ
Construction: Convoluted
Material: 304, 321, 316, Incoloy, Inconel, Nickel, Hastelloy
Profile: Medium Flexibility / High Pressure
Liner: Optional
Size Available: 2" - 24"
(Larger sizes upon Request)
Temperature: -196°C +900°C

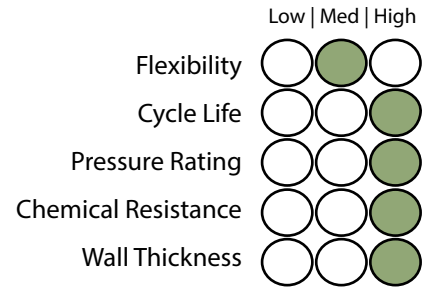

Construction

Use:
 Used for absorbing angular movement in any plane, movement of bellows is more controlled. Anchors only required to absorb spring forces, must be in pairs with another gimbal. Pressure thrust is restrained by the hardware.

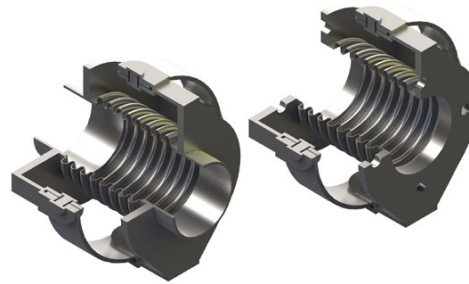

Specifications

Part Number	Nom	Length		Max. Working Pressure kPa	Movements		Spring Rate N/MM
	Bore	Flanged	Weld Ends		± Lateral	Total Lateral	
	(mm)	(mm)	(mm)		(mm)	(mm)	
50 GEJ-240	50	145	218	240	18	36	0.2
50 GEJ-700	50	145	218	700	18	36	0.6
50 GEJ-1400	50	145	218	1400	18	36	0.6
65 GEJ-240	65	180	234	240	18	36	0.2
65 GEJ-700	65	180	234	700	18	36	0.7
65 GEJ-1400	65	180	234	1400	18	36	1.3
80 GEJ-240	80	180	240	240	18	36	0.2
80 GEJ-700	80	180	240	700	18	36	0.6
80 GEJ-1400	80	180	240	1400	17	34	2.2
100 GEJ-240	100	190	278	240	18	36	1.3
100 GEJ-700	100	190	278	700	18	36	2.2
100 GEJ-1400	100	190	278	1400	17	34	4.6
125 GEJ-240	125	215	313	240	18	36	1.9
125 GEJ-700	125	215	313	700	18	36	3.4
125 GEJ-1400	125	215	313	1400	14	28	6.6
150 GEJ-240	150	215	338	240	18	36	2.3
150 GEJ-700	150	215	338	700	18	36	3.9
150 GEJ-1400	150	215	338	1400	14	28	18.2
200 GEJ-240	200	225	330	240	18	36	2.6
200 GEJ-700	200	225	330	700	17	34	9.8
200 GEJ-1400	200	225	330	1400	13	26	50
250 GEJ-240	250	245	341	240	18	36	4
250 GEJ-700	250	245	341	700	18	36	17

Additional sizes available. Visit www.hoseflex.com for our complete range



EXPANSION JOINTS

Double Gimbal Expansion Joint (DGEJ)

Expansion Joint - DGEJ

Part No.: DGEJ

Construction: Convoluted

Material: 304, 321, 316, Incoloy, Inconel, Nickel, Hastelloy

Profile: Medium Flexibility / High Pressure

Liner: Optional

Size Available: 2" - 24"

(Larger sizes upon Request)

Temperature : -196°C +900°C

Low | Med | High

Flexibility

Cycle Life

Pressure Rating

Chemical Resistance

Wall Thickness

Construction

Use:

Used for absorbing large amounts of lateral movement in one plane. Movement of bellows is more controlled. Anchors only required to absorb.



Specifications

Part Number	Nom	Length		Max. Working Pressure	Movements		Spring Rate
	Bore	Flanged	Weld Ends		± Lateral	Total Lateral	
	(mm)	(mm)	(mm)		(mm)	(mm)	
50 DGEJ-240	50	600	632	240	94	188	0.1
50 DGEJ-700	50	600	632	700	94	188	0.4
50 DGEJ-1400	50	600	632	1400	94	188	0.4
65 DGEJ-240	65	600	632	240	81	162	0.3
65 DGEJ-700	65	600	632	700	81	162	0.8
65 DGEJ-1400	65	600	632	1400	81	162	1.3
80 DGEJ-240	80	600	632	240	76	152	0.3
80 DGEJ-700	80	600	632	700	76	152	1.2
80 DGEJ-1400	80	600	632	1400	76	152	4.2
100 DGEJ-240	100	600	632	240	64	128	1.4
100 DGEJ-700	100	600	632	700	64	128	2.5
100 DGEJ-1400	100	600	632	1400	64	128	5.1
125 DGEJ-240	125	600	761	240	88	176	1.6
125 DGEJ-700	125	600	761	700	88	176	2.7
125 DGEJ-1400	125	600	761	1400	88	176	5.2
150 DGEJ-240	150	619	813	240	88	176	2.2
150 DGEJ-700	150	619	813	700	88	176	3.7
150 DGEJ-1400	150	619	813	1400	88	176	16.9
200 DGEJ-240	200	760	970	240	109	218	1.8
200 DGEJ-700	200	760	970	700	109	218	6.8
200 DGEJ-1400	200	760	970	1400	109	218	35
250 DGEJ-240	250	850	1060	240	114	228	3
250 DGEJ-700	250	850	1060	700	114	228	17

Additional sizes available. Visit www.hoseflex.com for our complete range

9
8
7
6
5
4
3
2
1

EXPANSION JOINTS

Single Tied Expansion Joint (TEJ)

Expansion Joint - TEJ

Part No.: TEJ
Construction: Convoluted
Material: 304, 321, 316, Incoloy, Inconel, Nickel, Hastelloy
Profile: Medium Flexibility / High Pressure
Liner: Optional
Size Available: 2" - 24"
(Larger sizes upon Request)
Temperature: -196°C +900°C

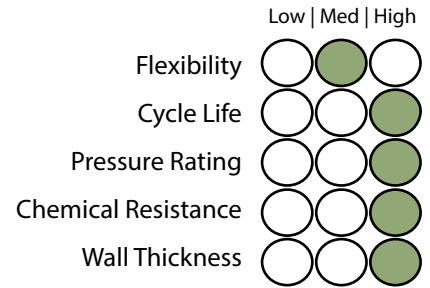

Construction

Use:
 Used for absorbing pump vibration, lateral movement and minor pipeline misalignment. Anchors required to absorb spring rate forces only. Pressure thrust is restrained by the tie rods.

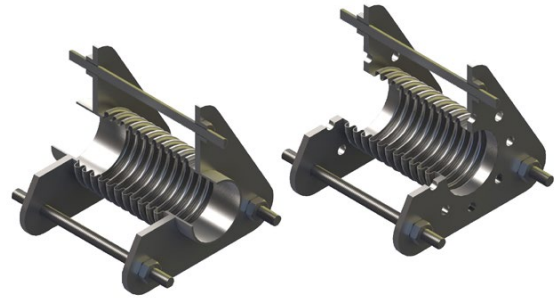

Specifications

Part Number	Nom	Length		Max. Working Pressure	Movements		Spring Rate
	Bore	Flanged	Weld Ends		± Lateral	Total Lateral	
	(mm)	(mm)	(mm)		(mm)	(mm)	
50 TEJ-240	50	145	218	240	12	24	12
50 TEJ-700	50	145	218	700	8	15	88
50 TEJ-1400	50	145	218	1400	7	13	88
65 TEJ-240	65	180	234	240	12	24	23
65 TEJ-700	65	180	234	700	11	21	70
65 TEJ-1400	65	180	234	1400	7	14	126
80 TEJ-240	80	180	240	240	13	25	18
80 TEJ-700	80	180	240	700	13	25	54
80 TEJ-1400	80	180	240	1400	8	16	198
100 TEJ-240	100	190	278	240	12	25	86
100 TEJ-700	100	190	278	700	10	20	152
100 TEJ-1400	100	190	278	1400	7	14	309
125 TEJ-240	125	215	313	240	13	26	111
125 TEJ-700	125	215	313	700	10	20	195
125 TEJ-1400	125	215	313	1400	7	14	381
150 TEJ-240	150	215	338	240	15	30	131
150 TEJ-700	150	215	338	700	9	18	228
150 TEJ-1400	150	215	338	1400	6	11	1048
200 TEJ-240	200	225	330	240	16	32	150
200 TEJ-700	200	225	330	700	9	18	562
200 TEJ-1400	200	225	330	1400	6	12	2897
250 TEJ-240	250	245	341	240	17	34	196
250 TEJ-700	250	245	341	700	10	19	855

Additional sizes available. Visit www.hoseflex.com for our complete range



EXPANSION JOINTS

Double Tied Expansion Joint (DTEJ)

Expansion Joint - DTEJ

Part No.: DTEJ

Construction: Convolute

Material: 304, 321, 316, Incoloy, Inconel, Nickel, Hastelloy

Profile: Medium Flexibility / High Pressure

Liner: Standard Flow Liner

Size Available: 2" - 24"

(Larger sizes upon Request)

Temperature: -196°C +900°C

Low | Med | High

Flexibility

Cycle Life

Pressure Rating

Chemical Resistance

Wall Thickness

Construction

Use:

Used for absorbing large amounts of lateral movement. Internal flow liners for eliminating velocity and flow problems may be fitted. Anchors required to absorb spring rate forces only. Pressure thrust is restrained by the tie rods.

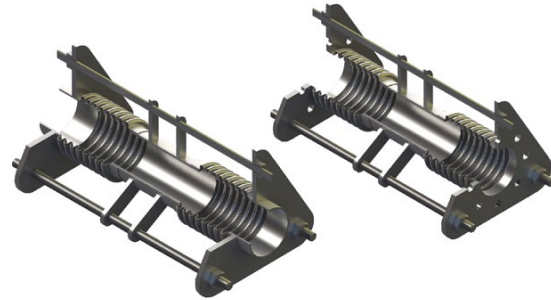

Specifications

Part Number	Nom	Length		Max. Working Pressure	Movements		Spring Rate
	Bore	Flanged	Weld Ends		± Lateral	Total Lateral	
	(mm)	(mm)	(mm)		(mm)	(mm)	
50 DTEJ-240	50	600	632	240	94	188	0.1
50 DTEJ-700	50	600	632	700	94	188	0.4
50 DTEJ-1400	50	600	632	1400	94	188	0.4
65 DTEJ-240	65	600	632	240	81	162	0.3
65 DTEJ-700	65	600	632	700	81	162	0.8
65 DTEJ-1400	65	600	632	1400	81	162	1.3
80 DTEJ-240	80	600	632	240	76	152	0.4
80 DTEJ-700	80	600	632	700	76	152	1.2
80 DTEJ-1400	80	600	632	1400	76	152	4.2
100 DTEJ-240	100	600	632	240	64	128	1.4
100 DTEJ-700	100	600	632	700	64	128	2.5
100 DTEJ-1400	100	600	632	1400	64	128	5.1
125 DTEJ-240	125	600	761	240	88	176	1.6
125 DTEJ-700	125	600	761	700	88	176	2.7
125 DTEJ-1400	125	600	761	1400	88	176	5.2
150 DTEJ-240	150	619	813	240	88	176	2.2
150 DTEJ-700	150	619	813	700	88	176	3.7
150 DTEJ-1400	150	619	813	1400	88	176	16.9
200 DTEJ-240	200	698	892	240	106	212	1.8
200 DTEJ-700	200	698	892	700	106	212	6.8
200 DTEJ-1400	200	698	892	1400	106	212	35
250 DTEJ-240	250	800	994	240	112	224	3
250 DTEJ-700	250	800	994	700	112	224	17

Additional sizes available. Visit www.hoseflex.com for our complete range

9
8
7
6
5
4
3
2
1

EXPANSION JOINTS

Double Tied Expansion Joint (DTEJ)

Double Tied Expansion Joint (DTEJ)

The double tied expansion joint is well suited to allow lateral deflection in the low to medium pressure range. Used in this manner the tie rods will absorb the pressure thrust. The design may also be used to absorb axial movement but this would result in the pressure thrust being taken from the tie rods and transmitted to the anchors or adjacent equipment.

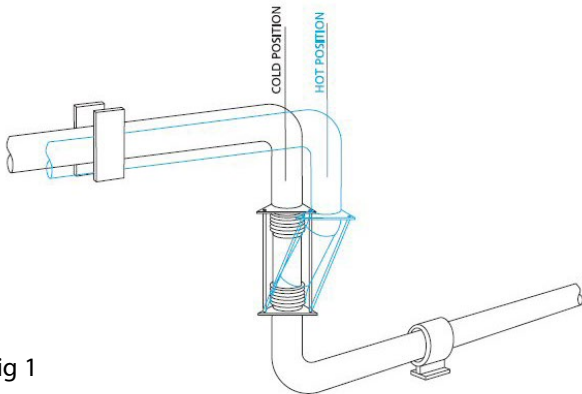

Fig 1

Fig 1 shows a double tied expansion joint used to absorb lateral deflection in a single plane. Wherever feasible the expansion joint should be designed to fill the entire leg so that the expansion of this leg is absorbed within the tie rods as axial movement.

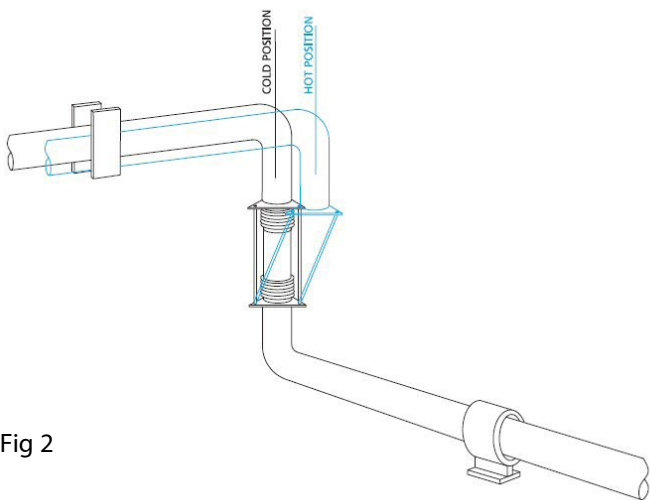

Fig 2

Fig 2 shows a double tied expansion joint used to absorb lateral deflection in a three-plane configuration. As the expansion joint will absorb lateral deflection in any direction, the two horizontal piping legs may lay at any angle in the horizontal plane.

To ensure that this style of joint is correctly installed without any thrust being transmitted to adjacent equipment, it may be necessary to utilize either double hinged or double gimbal expansion joints.

Seismic Joints and Expansion Loops

VITALFLEX® - Seismic Joints and Expansion Loops

Model name: VITALFLEX-V and VITALFLEX-U

VITALFLEX® seismic joints and expansion loops are engineered to account for the cumulative movement(s) in piping systems. The VITALFLEX® joints have been designed to counter thermal expansion/contraction, offset and rotation.

Piping used in locations subject to seismic conditions have their own set of unexpected random movements. The random motion common to earthquakes, requires that seismic expansion joints be capable of movement in any direction and are able to withstand the acceleration forces.

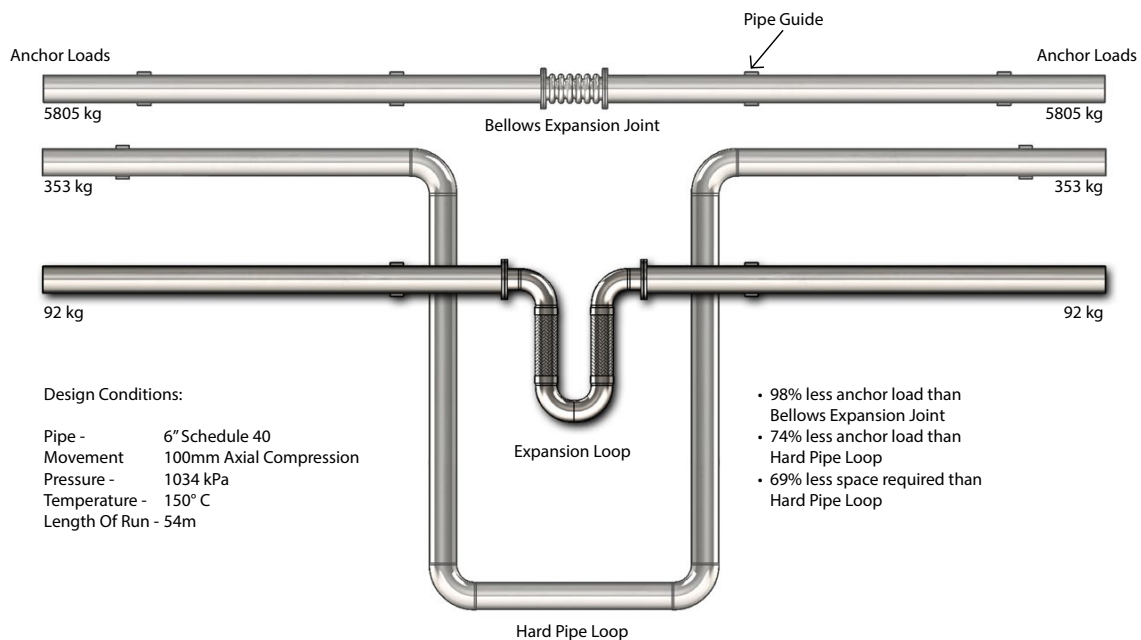

Significant cost and safety benefits found in VITALFLEX® seismic expansion joints

- It is an inexpensive alternative to dual-tied bellows expansion joints and especially ball joints
- During an earthquake, it protects equipment by allowing boilers, chillers, fan-coil units and other systems to move independently from buildings such as hospitals, high rises and stadiums
- Installation at the connection point, prevents nozzles from cracking or shearing off
- A break in the gas pipe work could start a fire and cause vast damage to the entire building. This Australian Gas Approval (AGA) certified seismic expansion joint will compensate for the movement that occurs during any seismic activity such as an earthquake
- Designed for potable water applications the VITALFLEX® joint can be Watermark certified in accordance with WMTS 520:2016

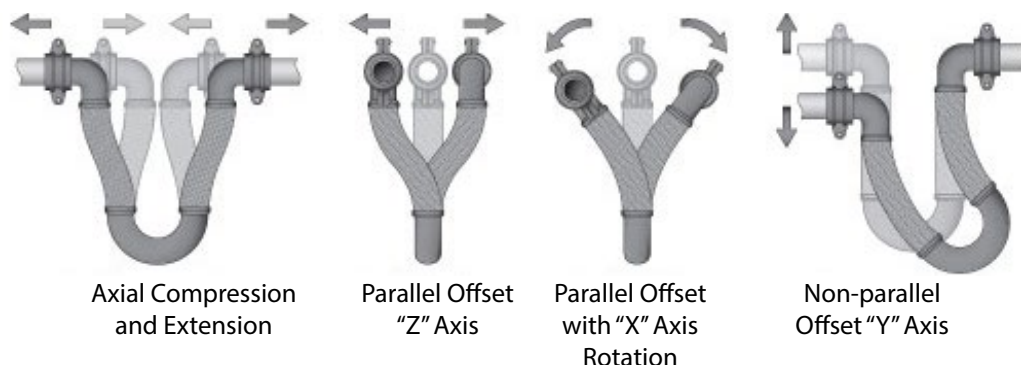

Seismic Expansion Joints

Installation Guide:

Reduce misalignment of the connecting pipes as any offset will change the design movements of the joint. When installing in any configuration other than with the product in a horizontal down position, the weight of the joint must be supported at the elbow connecting the two braided hoses. The recommended supports are wire cable or metal chain. These can be secured to the elbow used a pipe support clamp/bracket or on request to the hanging lugs which can be welded to the elbow in the manufacturing process.

Typical Installation:

HORIZONTAL
SIDE



HORIZONTAL
DOWN



HORIZONTAL
UP



NESTED



VERTICAL



UNDER-OVER



1
2
3
4
5
6
7
8
9

EXPANSION JOINTS

Seismic Expansion Joints

Maintenance Guide:

In the event of seismic activity or if excessive movements may have been applied, the product should be inspected to ensure that it has not incurred damage.

If there is an indication of evidence that the joint may have performed movements outside the design parameters this information should be communicated to Pacific Hoseflex to assess if the joints need to be repaired or replaced.

When the joints are visible a 12 monthly inspection should occur to enforce preventative maintenance.

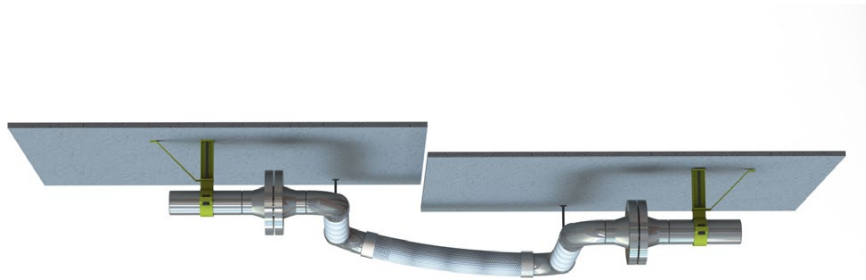
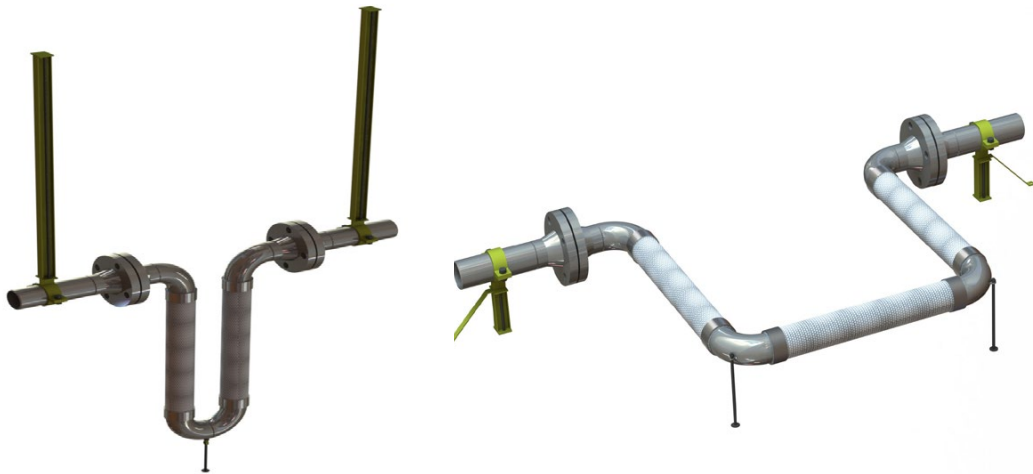

Seismic Expansion Joints

VITALFLEX® - V Shape

Construction: Annular / Close Pitch
Profile: High Flexibility / High Pressure
Material Available: 304 / 316 Stainless Steel
Braid Available: 304 / 316 Stainless Steel
Size Available: 1/4" (06mm) - 16" (500mm)
(Larger sizes upon Request)
Max Temp: 700°C

	Low	Med	High
Flexibility	<input type="radio"/>	<input type="radio"/>	<input checked="" type="radio"/>
Cycle Life	<input type="radio"/>	<input type="radio"/>	<input checked="" type="radio"/>
Pressure Rating	<input type="radio"/>	<input checked="" type="radio"/>	<input type="radio"/>
Chemical Resistance	<input type="radio"/>	<input type="radio"/>	<input checked="" type="radio"/>
Wall Thickness	<input type="radio"/>	<input checked="" type="radio"/>	<input type="radio"/>

Installations:

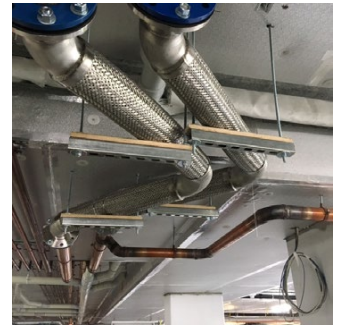

Couplings:

VITALFLEX® - Swivel Flange
Model Name: VITALFLEX-V-AF4



VITALFLEX® - Rolled groove coupling
Model Name: VITALFLEX-V-RG



VITALFLEX® - Male coupling
Model Name: VITALFLEX-V-AF1



VITALFLEX® - Female Union coupling
Model Name: VITALFLEX-V-AF12



Seismic Expansion Joints (V Shape)

Specifications

Movement range: Up to +/- 500mm
 (Standard catalogue range: 50mm, 75mm, 100mm, 150mm and 200mm)
 (Customised movement available upon request from 0 to > 500 mm)

Pressure range:

WaterMark: Full Vacuum up to 2500 kPa
 (Compressed hose may be considered for negative pressure/vacuum applications)
 (Temperature correction factors may apply)
 (Pressure restrictions may apply related to pressure rating of end fittings used)

Standards:

Corrugated Metal Hoses: ISO 10380
 AGA Approved: AS 4631 (upon request)
 Watermark Approved: WMTS 520 (upon request)
 Welding Compliant: AS 4041- Class 1 (upon request)
 Seismic Rated: AS 1170 (upon request)
 Fire Protection Systems (upon request)

AGA (Australian Gas Association):

Full Vacuum up to 1500 kPa
 (Compressed hose may be considered for negative pressure/vacuum applications)
 (Temperature correction factors may apply)
 (Pressure restrictions may apply related to pressure rating of end fittings used)

Temperature range: -276 °C to 700 °C

(Restrictions from applicable standards for assemblies and end fittings may apply)
 (Calculated values available for single braided hose MAOP, double braided hose MAOP, 100 kPa, 500 kPa, 800 kPa, 1000 kPa, 1200 kPa,, 1500 kPa, 2000 kPa 2500 kPa)

Pressure thrust range: 0.01 kN to 147.39 kN

(Calculated values available for single braided hose MAOP, double braided hose MAOP, 100 kPa, 500 kPa, 800 kPa, 1000 kPa, 1200 kPa,, 1500 kPa, 2000 kPa 2500 kPa)

Unit weight range: Refer to technical catalogue for unfilled and filled water values
 (Available on request)

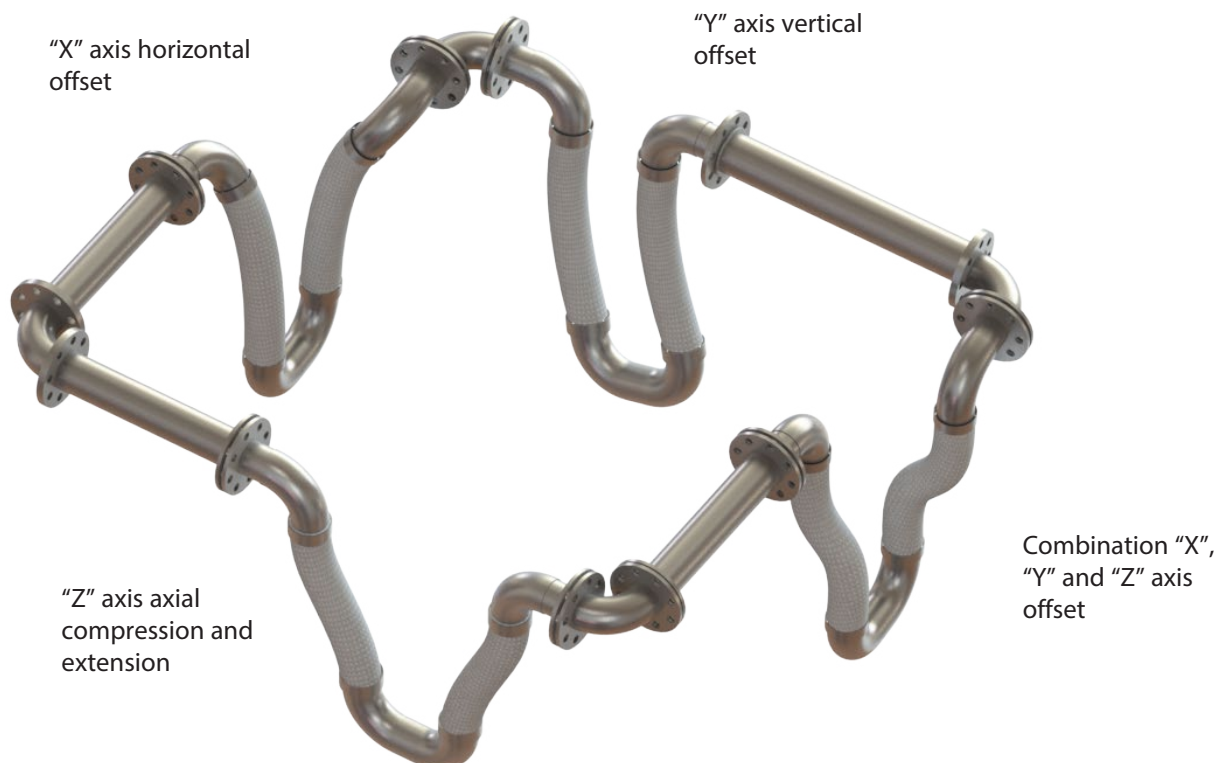

"X" axis horizontal offset

"Y" axis vertical offset

"Z" axis axial compression and extension

Combination "X", "Y" and "Z" axis offset



Seismic Expansion Joints

VITALFLEX® - V Shape

Construction: Annular / Close Pitch
Profile: High Flexibility / High Pressure
Material Available: 304 / 316 Stainless Steel
Braid Available: 304 / 316 Stainless Steel
Size Available: 1/4" (06mm) - 16" (500mm)
(Larger sizes upon Request)
Max Temp: 700°C

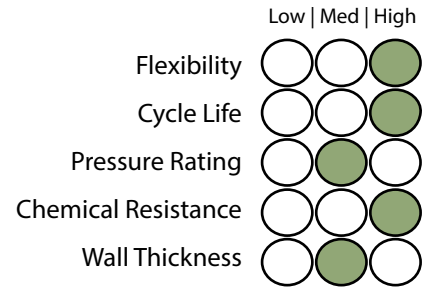

Construction

Use:
 Used in a variety of applications and locations where subject to seismic conditions or large amounts of pipework movement. The random motion common to earthquakes requires that seismic expansion joints to be capable of movement in any direction.

Standards:
 Corrugated Metal Hoses: ISO 10380
 AGA Approved: AS 4631 (upon request)
 Watermark Approved: WMTS 520 (upon request)
 Welding Compliant: AS 4041- Class 1 (upon request)
 Seismic Rated: AS 1170 (upon request)
 Seismic rated: NZS 4219 – 2009 (upon request)
 Fire Protection Systems (upon request)



WaterMark

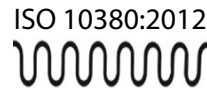

Specifications

Hose Size (mm)	Hose Size (inch)	Model	MOVEMENT (mm)	Dimension A	Dimension B	Pressure (kPa) @ 23 deg c	Hydrostatically Filled Hose weight (kg) (+/- 5%) Excluding all pipe bends and end fittings	Pneumatically Filled Hose weight (kg) (+/- 5%) Excluding all pipe bends and end fittings	Hose Spring Rate (Kg/Cm)	Hose Pipe load (kgs)
12	1/2"	VITALFLEX-V-12	50	331	150	8445	0.129	0.078	0.31	1.550
20	3/4"	VITALFLEX-V-20	50	351	160	7128	0.311	0.173	0.88	4.400
25	1"	VITALFLEX-V-25	50	367	167	5487	0.432	0.221	1.13	5.650
32	1 1/4"	VITALFLEX-V-32	50	436	198	4136	0.819	0.402	1.49	7.450
38	1 1/2"	VITALFLEX-V-38	50	483	218	3840	1.205	0.560	2.00	10.000
50	2"	VITALFLEX-V-50	50	548	242	3930	1.905	0.869	2.67	13.350
65	2 1/2"	VITALFLEX-V-65	50	684	302	2826	3.825	1.417	2.52	12.600
75	3"	VITALFLEX-V-75	50	760	333	2310	5.453	1.854	7.94	39.700
100	4"	VITALFLEX-V-100	50	915	394	1654	9.456	2.772	8.53	42.650
125	5"	VITALFLEX-V-125	50	1057	450	1316	15.457	4.392	8.59	42.950
150	6"	VITALFLEX-V-150	50	1205	508	1137	21.866	5.410	9.44	47.200
200	8"	VITALFLEX-V-200	50	1450	599	1643	39.335	9.276	24.47	122.350
250	10"	VITALFLEX-V-250	50	1734	709	1585	72.582	20.674	39.76	198.800
300	12"	VITALFLEX-V-300	50	2228	893	1110	134.914	35.626	27.76	138.800

EXPANSION JOINTS 1 2 3 4 5 6 7 8 9

Seismic Expansion Joints

VITALFLEX® - V Shape

Hose Size (mm)	Hose Size (inch)	Model	MOVEMENT (mm)	Dimension A	Dimension B	Pressure (kPa) @ 23 deg c	Hydrostatically Filled Hose weight (kg) (+/- 5%) Excluding all pipe bends and end fittings	Pneumatically Filled Hose weight (kg) (+/- 5%) Excluding all pipe bends and end fittings	Hose Spring Rate (Kg/Cm)	Hose Pipe load (kgs)
12	1/2"	VITALFLEX-V-12	100	432	200	8445	0.187	0.113	0.1	1
20	3/4"	VITALFLEX-V-20	100	460	214	7128	0.459	0.255	0.12	1.2
25	1"	VITALFLEX-V-25	100	481	225	5487	0.648	0.331	0.3	3
32	1 1/4"	VITALFLEX-V-32	100	567	264	4136	1.218	0.597	0.46	4.6
38	1 1/2"	VITALFLEX-V-38	100	623	288	3840	1.781	0.827	0.63	6.3
50	2"	VITALFLEX-V-50	100	691	314	3930	2.791	1.274	0.85	8.5
65	2 1/2"	VITALFLEX-V-65	100	860	391	2826	5.583	2.069	0.78	7.8
75	3"	VITALFLEX-V-75	100	946	426	2310	7.925	2.694	2.73	27.3
100	4"	VITALFLEX-V-100	100	1119	496	1654	13.595	3.985	2.844	28.44
125	5"	VITALFLEX-V-125	100	1275	559	1316	22.144	6.293	2.92	29.2
150	6"	VITALFLEX-V-150	100	1439	625	1137	31.238	7.729	3.2	32
200	8"	VITALFLEX-V-200	100	1697	722	1643	56.151	13.241	8.29	82.9
250	10"	VITALFLEX-V-250	100	2010	847	1585	103.327	29.431	13.69	136.9
300	12"	VITALFLEX-V-300	100	2528	1043	1110	180.028	47.539	11.45	114.5

Note :

Dimension 'A' and 'B' are approx dimensions without Fitting only and are subject to change without notice.

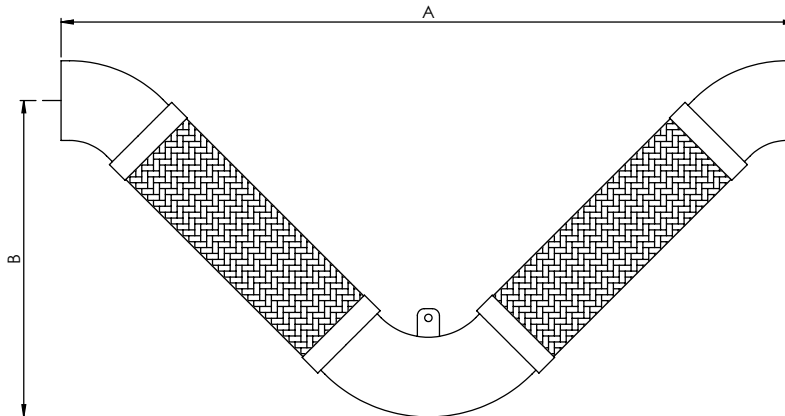

Applications



9
8
7
6
5
4
3
2
1
EXPANSION JOINTS

Seismic Expansion Joints

Expansion Joint - U Shape

Construction: Annular / Close Pitch
Profile: High Flexibility / High Pressure
Material Available: 304 / 316 Stainless Steel
Braid Available: 304 / 316 Stainless Steel
Size Available: 1/4" (06mm) - 16" (500mm)
(Larger sizes upon Request)
Max Temp: 700°C

	Low	Med	High
Flexibility	<input type="radio"/>	<input type="radio"/>	<input checked="" type="radio"/>
Cycle Life	<input type="radio"/>	<input type="radio"/>	<input checked="" type="radio"/>
Pressure Rating	<input type="radio"/>	<input checked="" type="radio"/>	<input type="radio"/>
Chemical Resistance	<input type="radio"/>	<input type="radio"/>	<input checked="" type="radio"/>
Wall Thickness	<input type="radio"/>	<input checked="" type="radio"/>	<input type="radio"/>

Installation:

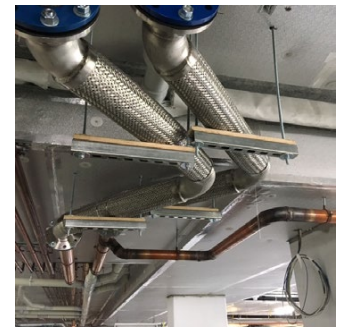

Couplings:

VITALFLEX® - Swivel Flange
Model Name: VITALFLEX-U-AF4



VITALFLEX® - Rolled groove coupling
Model Name: VITALFLEX-U-RG



VITALFLEX® - Male coupling
Model Name: VITALFLEX-U-AF1



VITALFLEX® - Female Union coupling
Model Name: VITALFLEX-U-AF12



Seismic Expansion Joints (U Shape)

Specifications

Movement range: Up to +/- 500mm

(Standard catalogue range: 50mm, 75mm, 100mm, 150mm and 200mm)

(Customised movement available upon request from 0 to > 500 mm)

Pressure range:

WaterMark: Full Vacuum up to 2500 kPa

(Compressed hose may be considered for negative pressure/vacuum applications)

(Temperature correction factors may apply)

(Pressure restrictions may apply related to pressure rating of end fittings used)

Standards:

Corrugated Metal Hoses: ISO 10380

AGA Approved: AS 4631 (upon request)

Watermark Approved: WMTS 520 (upon request)

Welding Compliant: AS 4041- Class 1 (upon request)

Seismic Rated: AS 1170 (upon request)

Fire Protection Systems (upon request)

AGA (Australian Gas Association): Full

Vacuum up to 1500 kPa

(Compressed hose may be considered for negative pressure/vacuum applications)

(Temperature correction factors may apply)

(Pressure restrictions may apply related to pressure rating of end fittings used)

Temperature range: -276 °C to 700 °C

(Restrictions from applicable standards for assemblies and end fittings may apply)

(Calculated values available for single braided hose MAOP, double braided hose MAOP, 100 kPa, 500 kPa, 800 kPa, 1000 kPa, 1200 kPa,, 1500 kPa, 2000 kPa 2500 kPa)

Pressure thrust range: 0.01 kN to 147.39 kN

(Calculated values available for single braided hose MAOP, double braided hose MAOP, 100 kPa, 500 kPa, 800 kPa, 1000 kPa, 1200 kPa,, 1500 kPa, 2000 kPa 2500 kPa)

Unit weight range: Refer to technical catalogue for unfilled and filled water values (Available on request)

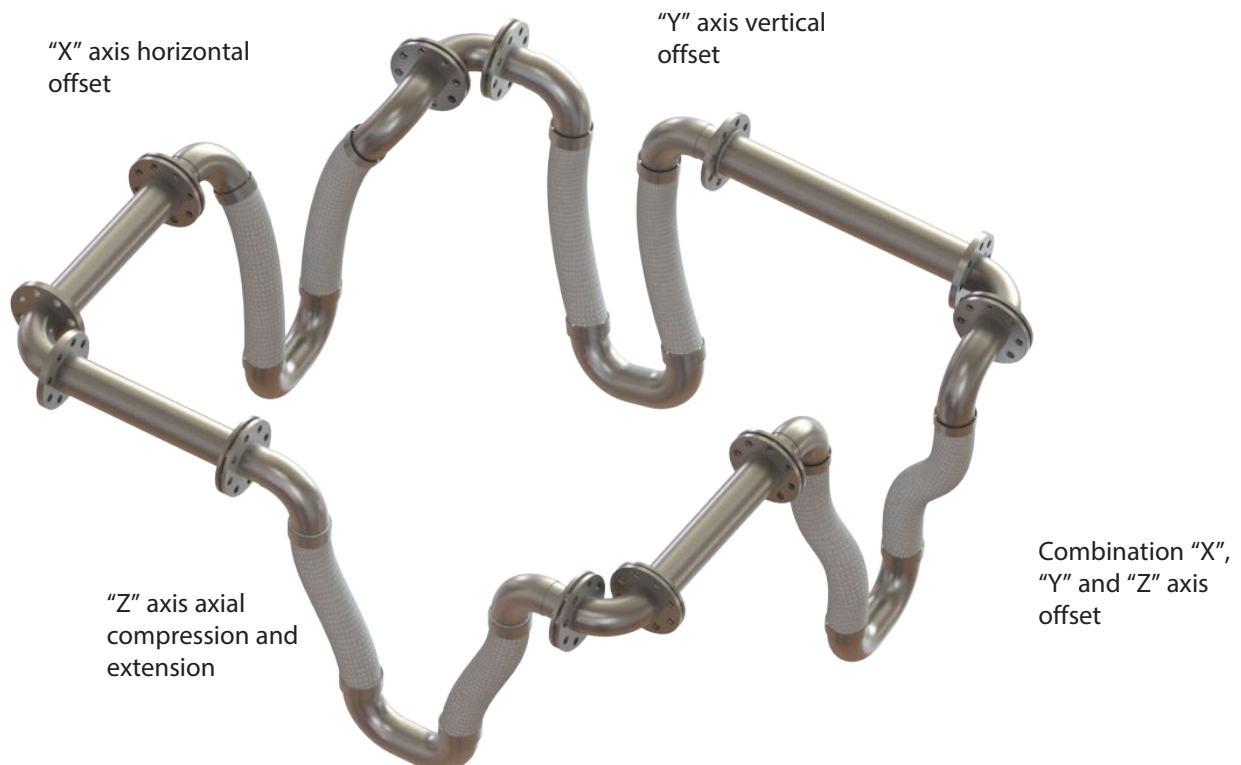



Seismic Expansion Joints

Expansion Joint - U Shape

Construction: Annular / Close Pitch
Profile: High Flexibility / High Pressure
Material Available: 304 / 316 Stainless Steel
Braid Available: 304 / 316 Stainless Steel
Size Available: 1/4" (06mm) - 16" (500mm)
(Larger sizes upon Request)
Max Temp: 700°C

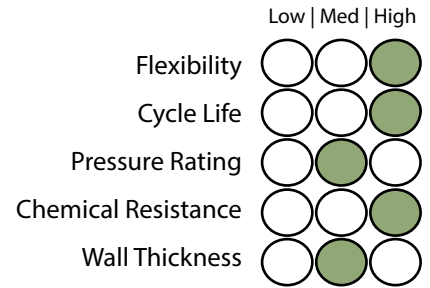

Construction

Use:
 Used in a variety of applications and locations where subject to seismic conditions or large amounts of pipework movement. The random motion common to earthquakes requires that seismic expansion joints to be capable of movement in any direction.

Standards:
 Corrugated Metal Hoses: ISO 10380
 AGA Approved: AS 4631 (upon request)
 Watermark Approved: WMTS 520 (upon request)
 Welding Compliant: AS 4041- Class 1 (upon request)
 Seismic Rated: AS 1170 (upon request)
 Seismic Rated: NZS 4219 - 2009 (upon request)
 Fire Protection Systems (upon request)

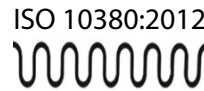

Specifications

Hose Size (mm)	Hose Size (inch)	Model	MOVEMENT (mm)	Dimension A	Dimension B	Pressure (kPa) @ 23 deg c	Hydrostatically Filled Hose weight (kg) (+/- 5%) Excluding all pipe bends and end fittings	Pneumatically Filled Hose weight (kg) (+/- 5%) Excluding all pipe bends and end fittings	Hose Spring Rate (Kg/Cm)	Hose Pipe load (kgs)
12	1/2"	VITALFLEX-U-12	50	202	245	8445	0.131	0.079	0.31	1.55
20	3/4"	VITALFLEX-U-20	50	202	262	7128	0.336	0.187	0.73	3.65
25	1"	VITALFLEX-U-25	50	202	276	5487	0.488	0.249	0.75	3.75
32	1 1/4"	VITALFLEX-U-32	50	240	329	4136	0.909	0.446	0.96	4.8
38	1 1/2"	VITALFLEX-U-38	50	279	366	3840	1.327	0.616	1.26	6.3
50	2"	VITALFLEX-U-50	50	355	417	3930	2.063	0.941	1.68	8.4
65	2 1/2"	VITALFLEX-U-65	50	381	522	2826	4.149	1.537	1.64	8.2
75	3"	VITALFLEX-U-75	50	457	582	2310	5.830	1.982	5.27	26.35
100	4"	VITALFLEX-U-100	50	610	704	1654	9.830	2.881	5.46	27.3
125	5"	VITALFLEX-U-125	50	762	817	1316	15.848	4.503	5.55	27.75
150	6"	VITALFLEX-U-150	50	914	934	1137	22.321	5.523	5.58	27.9
200	8"	VITALFLEX-U-200	50	1219	1134	1643	40.108	9.458	12.21	61.05
250	10"	VITALFLEX-U-250	50	1524	1410	1585	81.140	23.111	16.29	81.45
300	12"	VITALFLEX-U-300	50	1829	1582	1110	107.676	28.433	26.73	133.65

EXPANSION JOINTS

Seismic Expansion Joints

Expansion Joint - U Shape

Hose Size (mm)	Hose Size (inch)	Model	MOVEMENT (mm)	Dimension A	Dimension B	Pressure (kPa) @ 23 deg c	Hydrostatically Filled Hose weight (kg) (+/- 5%) Excluding all pipe bends and end fittings	Pneumatically Filled Hose weight (kg) (+/- 5%) Excluding all pipe bends and end fittings	Hose Spring Rate (Kg/Cm)	Hose Pipe load (kgs)
12	1/2"	VITALFLEX-U-12	100	252	322	8445	0.190	0.115	0.11	1.1
20	3/4"	VITALFLEX-U-20	100	252	342	7128	0.480	0.267	0.25	2.5
25	1"	VITALFLEX-U-25	100	252	357	5487	0.704	0.359	0.28	2.8
32	1 1/4"	VITALFLEX-U-32	100	290	422	4136	1.308	0.641	0.35	3.5
38	1 1/2"	VITALFLEX-U-38	100	329	465	3840	1.903	0.884	0.47	4.7
50	2"	VITALFLEX-U-50	100	405	519	3930	2.958	1.350	0.69	6.9
65	2 1/2"	VITALFLEX-U-65	100	481	646	2826	5.893	2.183	0.61	6.1
75	3"	VITALFLEX-U-75	100	557	714	2310	8.321	2.829	1.99	19.9
100	4"	VITALFLEX-U-100	100	610	849	1654	13.998	4.103	2.07	20.7
125	5"	VITALFLEX-U-125	100	762	972	1316	22.578	6.416	2.15	21.5
150	6"	VITALFLEX-U-150	100	914	1100	1137	31.749	7.855	2.27	22.7
200	8"	VITALFLEX-U-200	100	1219	1308	1643	56.924	13.424	5.47	54.7
250	10"	VITALFLEX-U-250	100	1524	1555	1585	104.119	29.657	8.83	88.3
300	12"	VITALFLEX-U-300	100	1829	1795	1110	153.002	40.403	11.62	116.2

Note :
- Dimension 'A' and 'B' are approx dimensions without Fitting only and are subject to change without notice.

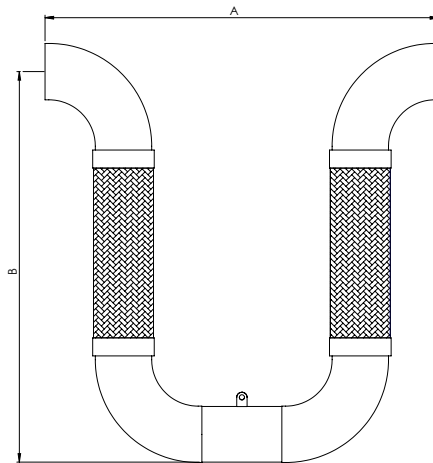

Applications

